



# SF1 Stainless Steel Filter w/ Cyclone Separator

## Features

All stainless steel separator filter efficiently removes condensate and impurities from the flow medium. Suitable for applications requiring high-quality dry steam, and non-hazardous gas mains.

1. Built-in cyclone separator eliminates condensate, dirt and scale before filtering, extending filter maintenance cycle.
2. Separator achieves condensate separation efficiency as high as 98%.
3. Easy-to-clean five layer sintered wire mesh filter maintains extremely low pressure drop for extended periods.
4. Compact and lightweight.
5. Ferrule joint clamp facilitates cleaning and disassembling, reducing maintenance costs.



## Pressure Equipment Directive (PED)

Classification according to PED 2014/68/EU, fluid group 2

Size	Category	CE marking
DN 15 to DN 40	—*	Art. 4, Sec. 3 (sound engineering practice), CE marking not allowed
DN 50	I	With CE marking and Declaration of Conformity

\* Manufactured in accordance with sound engineering practice

## Specifications

Model	SF1		
Connection	Screwed	Socket Welded	Flanged
Size	½", ¾", 1", 1½", 2"	DN 15, 20, 25, 40, 50	
Washing/Pressure Detection Port Connection	½" Screwed		
Condensate Outlet Connection	½" Screwed		
Maximum Operating Pressure (barg) PMO	10		
Maximum Operating Temperature (°C) TMO	185		
Nominal Filter Rating <sup>1)</sup> (µm)	0.5, 2, 5, 10 <sup>4)</sup> , 40 <sup>4)</sup>		
Filter Construction	Five layer Sintered Wire Mesh		
Internal & External Finishing <sup>2)</sup>	Acid Cleaning (lost-wax cast)		
Applicable Fluids <sup>3)</sup>	Steam, Air		

<sup>1)</sup> Consult TLV for other available filter ratings <sup>2)</sup> Optional electro-polishing (lost-wax cast) available on request

1 bar = 0.1 MPa

<sup>3)</sup> Do not use for toxic, flammable or otherwise hazardous fluids <sup>4)</sup> Optional

PRESSURE SHELL DESIGN CONDITIONS (**NOT** OPERATING CONDITIONS): Maximum Allowable Pressure (barg) PMA: 10  
Maximum Allowable Temperature (°C) TMA: 185



To avoid abnormal operation, accidents or serious injury, DO NOT use this product outside of the specification range. Local regulations may restrict the use of this product to below the conditions quoted.

# Configuration

No.	Description	Material	DIN <sup>1)</sup>	ASTM/AISI <sup>1)</sup>	
①	Body	Cast Stainl. Steel A351 Gr.CF8	1.4312	—	
②	Separator	Cast Stainl. Steel A351 Gr.CF8	1.4312	—	
③	Separator Body	DN 15-25	Cast Stainl. Steel A351 Gr.CF8	1.4312	—
		DN 40, DN 50	Cast Stainl. Steel A351 Gr.CF8/ Stainless Steel SUS304	1.4312/1.4301	- /AISI304
④	Separator Bottom	Cast Stainl. Steel A351 Gr.CF8	1.4312	—	
⑤	Baffle	Stainless Steel SUS304	1.4301	AISI304	
⑥	Filter	Stainless Steel SUS304/316/ 316L <sup>2)</sup>	1.4301/1.4401/ 1.4404	AISI304/316/ 316L	
⑦	Filter Gasket <sup>3)</sup>	High-performance Fluorine Resin	—	—	
⑧	Body Clamp <sup>4)</sup>	Cast Stainl. Steel A351 Gr.CF8	1.4312	—	
⑨	Body Gasket <sup>3)</sup>	High-performance Fluorine Resin	—	—	
⑩	Nameplate	Stainless Steel SUS304	1.4301	AISI304	
⑪	Plug	Stainless Steel SUS304	1.4301	AISI304	
⑫	Clamp Bolt <sup>5)</sup>	Stainless Steel SUS304	1.4301	AISI304	
⑬	Clamp Nut <sup>5)</sup>	Stainless Steel SUS304	1.4301	AISI304	
⑭	Spring Washer <sup>5)</sup>	Stainless Steel SUS304	1.4301	AISI304	
⑮	Flange <sup>6)</sup>	Cast Stainl. Steel A351 Gr.CF8/ Stainless Steel SUS304 <sup>2)</sup>	1.4312/1.4301	- /AISI304	

<sup>1)</sup> Equivalent materials <sup>2)</sup> Material depends on filter rating or flange specifications  
<sup>3)</sup> Gasket is GYLON BIO-PRO; complies with FDA/USP/EN standards. See table above-right for details. GYLON BIO-PRO is a registered trademark of Garlock GmbH.  
<sup>4)</sup> Two-piece two-bolt clamp <sup>5)</sup> Not shown <sup>6)</sup> See "Dimensions".

Parts with USP/FDA/EN Compliant Materials		Standard			
		USP	FDA*	EN	
⑦	Filter Gasket	High-performance Fluorine Resin	Class VI	A	1935
⑨	Body Gasket	Fluorine Resin	—	B	—
⑪	Seal Tape for Plug	Fluorine Resin	—	B	—

\* FDA: A: 21 CFR 177.1550, B: 21 CFR 177.1615

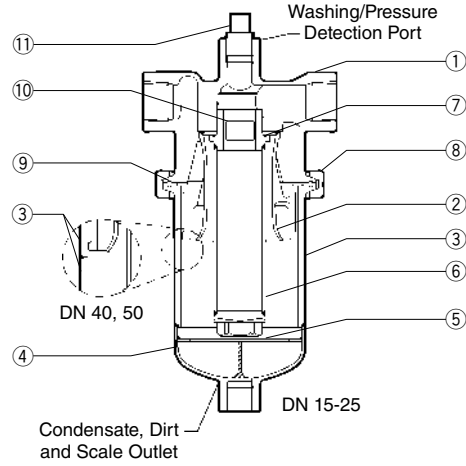

# Dimensions

## ● SF1 Screwed

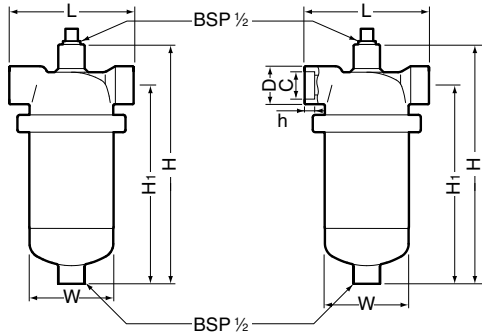

## Socket Welded

## SF1 Screwed\*/Socket Welded\*\*

(mm)

Size	DN	L	H	H <sub>1</sub>	φW	φD	φC	h	Weight (kg)
1/2"	15	130	255	210	89	36	21.8	13	4.5
3/4"	20								
1"	25	150	290	240	101	44	33.9	16	6.0
1 1/2"	40	170	460	405	115	59	48.8		11
2"	50	220	565	505	165	72	61.2	16	22

\* DIN EN 10226, other standards available

\*\* ASME B16.11-2005, other standards available

## ● SF1 Flanged

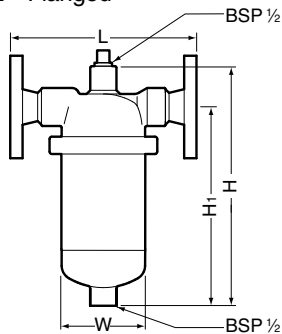

## SF1 Flanged

(mm)

DN	L		H	H <sub>1</sub>	φW	Weight* (kg)
	DIN EN 1092-1 PN25/40	ASME Class 150RF				
15	202	191	255	210	89	6.2
20						6.8
25						8.7
40						16
50						28

Other standards available, but length and weigh may vary

\* Weight is for DIN PN 25/40

## Steam Pressure Loss

● 0.5 µm Filter

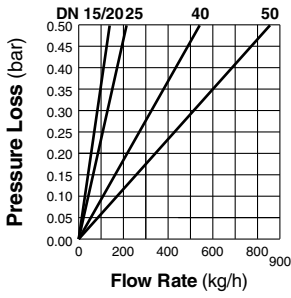

● 2 µm Filter

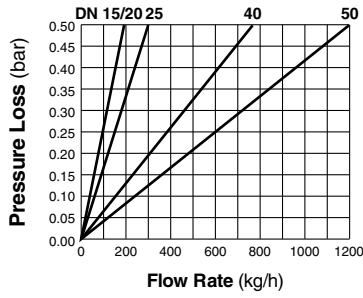

● 5 µm Filter

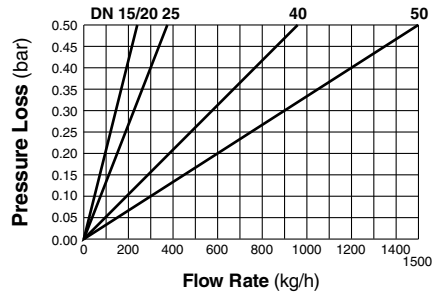

● 10 µm Filter\*

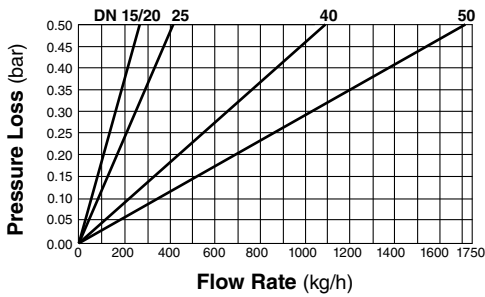

● 40 µm Filter\*

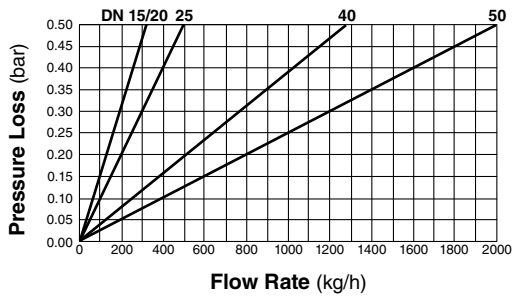

\* Option

These pressure loss charts are based on a steam pressure of 1 barg. For other pressures, multiply the steam flow rate by the correction factor given in the table right. Use the result on the pressure loss chart.

Pressure (barg)	1	2	3	4	5	6	7	8	9	10
Flow Rate Correction Factor	1.0	0.83	0.72	0.65	0.60	0.56	0.52	0.49	0.47	0.45

## Steam Flow Rate

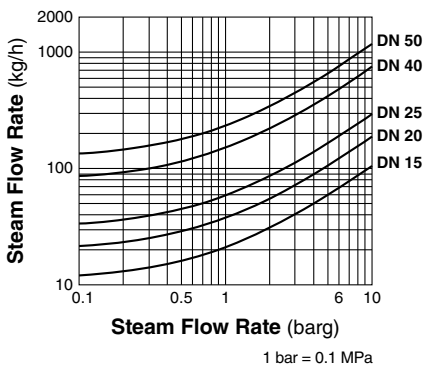

The chart to the left is used to determine the steam flow rate through the SF1 separator-filter. It is based on a steam velocity in the piping of 30 m/s. For other cases, use the equation below and replace "v" with your steam velocity:

$$\text{Effective flow rate} = \text{Flow rate}_{30 \text{ m/s}} \times \frac{v}{30}$$

It is recommended that steam velocities not exceed 30 m/s.

Note: For pressure loss and flow rate of air, contact TLV.