



P46SRN/P46SRM/P46SRW 'PowerDyne' Thermodynamic Disc Type Steam Trap

Features

Inline repairable trap for steam mains, tracers and coils, with wide capacity range to match various conditions. Available in carbon steel or stainless steel.

1. Inline replaceable module valve seat.
2. Air jacketing reduces no-load cycling.
3. Lapped disc provides steam-tight seal without air binding.
4. Built-in screen for trouble-free service.
5. Bimetal ring provides quick thermostatic air venting.
6. Hardened stainless steel working surfaces.



Pressure Equipment Directive (PED)

Classification according to PED 2014/68/EU, fluid group 2

Size	Category	CE marking
DN 15 to 32	—*	Art. 4, Sec. 3 (sound engineering practice), CE marking not allowed
DN 40, DN 50	I	with CE marking and Declaration of Conformity

* Manufactured in accordance with sound engineering practice

Specifications

Model	P46SRN				P46SRM				P46SRW				
	Carbon Steel (C22.8 / A105 ¹⁾)		Stainless Steel ²⁾ (A182 F304) (equivalent to 1.4301)		Carbon Steel (C22.8 / A105 ¹⁾)		Stainless Steel ²⁾ (A182 F304) (equivalent to 1.4301)		Cast Steel (A216 Gr.WCB) (equivalent to 1.0619)				
Connection	Screwed	S. Welded	Flanged	Screwed	S. Welded	Screwed	S. Welded	Flanged	Screwed	S. Welded	Screwed	S. Welded	Flanged
Size	1/2, 3/4, 1"	DN15, 20, 25	DN15, 20, 25	1/2, 3/4, 1"	DN15, 20, 25	1/2, 3/4, 1"	DN15, 20, 25	1/2, 3/4, 1"	DN15, 20, 25	1"	DN25	DN25, 32, 40, 50	
Max. Operating Press. (barg) PMO	46												
Min. Operating Press. (barg)	0.3												
Max. Operating Temp. (°C) TMO	400 ³⁾ / 425												
Maximum Back Pressure	80% of inlet pressure												
Max. Allowable Press. (barg) PMA ⁴⁾	82 @ 40°C		89 @ 40°C		82 @ 40°C		89 @ 40°C		70 @ 40°C				
Max. Allowable Temp. (°C) TMA ⁴⁾	425 @ 50 barg		400 ³⁾ / 425 @ 50 barg		550 @ 46 barg		425 @ 50 barg		400 ³⁾ / 425 @ 50 barg		425 @ 50 barg		400 ³⁾ / 425 @ 50 barg

¹⁾ With ASME Flange ²⁾ Contact TLV for optional flanged stainless steel model. ³⁾ With PN Flange ⁴⁾ PRESSURE SHELL DESIGN CONDITIONS (NOT OPERATING CONDITIONS). Refer to Pressure Temperature Rating section on reverse side for details

1 bar = 0.1 MPa



To avoid abnormal operation, accidents or serious injury, DO NOT use this product outside of the specification range. Local regulations may restrict the use of this product to below the conditions quoted.

No.	Description	Material	DIN*	ASTM/AISI*
①	Body	See Specifications table for available materials		
② ^R	Module Valve Seat	Stainless Steel SUS420F	1.4028	AISI420F
③ ^R	Cover	Stainless Steel A182 F304	1.4301	—
④ ^R	Disc	Stainless Steel SUS420J2	1.4031	AISI420
⑤ ^R	Disc Holder Ring	Stainless Steel SUS420J2	1.4031	AISI420
⑥ ^R	Air Vent Ring	Bimetal	—	—
⑦ ^{MR}	Outer Module Gasket	Graphite/Stainl. Stl. SUS316L	- /1.4404	- /AISI316L
⑧ ^R	Nameplate	Stainless Steel SUS304	1.4301	AISI304
⑨ ^{MR}	Inner Module Gasket	Graphite/Stainl. Stl. SUS316L	- /1.4404	- /AISI316L
⑩ ^R	Screen inside/outside	Stainless Steel SUS304/430	1.4301/1.4016	AISI304/430
⑪ ^{MR}	Screen Holder Gasket	Soft Iron SUYP	1.1121	AISI1010
		Stainless Steel SUS316L**	1.4404	AISI316L
⑫	Screen Holder	Cast Stainl. Steel A351 Gr.CF8	1.4312	—
⑬ ^R	Cap	Stainless Steel SUS304	1.4301	AISI304
⑭	Flange***	Carbon Steel C22.8	1.0460	A105
		Carbon Steel A105	1.0460	—

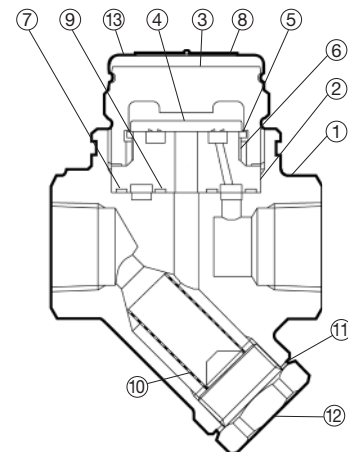

* Equivalent materials ** For models with stainless steel body
*** Shown on reverse, shape and material depend on flange specifications
Replacement kits available: (M) maintenance parts, (R) repair parts

Dimensions

● P46SRN/P46SRM/P46SRW Screwed

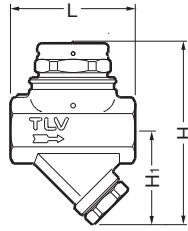

● P46SRN/P46SRM/P46SRW Socket Welded

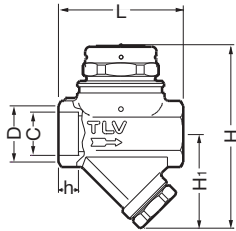

● P46SRN/P46SRM/P46SRW Flanged

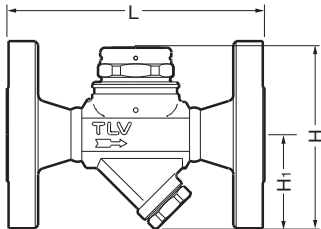

P46SRN/P46SRM/P46SRW Screwed* (mm)

Size	L	H	H ₁	Weight (kg)
1/2"	80	120	62	1.2
3/4"				1.4 (1.6)
1"	88	125 (129)		

() Model P46SRW

* BSP DIN 2999, other standards available

P46SRN/P46SRM/P46SRW Socket Welded* (mm)

DN	L	H	H ₁	ϕD	ϕC	h	Weight (kg)
15	80	120	62	30	21.8	13	1.2
20				36	27.2		
25	88	125 (129)		44	33.9	13 (14)	1.4 (1.6)

() Model P46SRW

* ASME B16.11-2005, other standards available

P46SRN/P46SRM/P46SRW Flanged (mm)

DN	L				H	H ₁	Weight ²⁾ (kg)
	DIN 2501 PN25/40	ASME Class ¹⁾					
15	150	140	140	140	120	62	2.7
20		165	165	165			3.7
25	160	210	210	210	120 (129)		5.0 (4.1)
32 ³⁾	—				4.7 ⁴⁾		
40 ³⁾	230	220	220	220	129		5.7
50 ³⁾					7.0		

() Model P46SRW

Other standards available, but length and weight may vary

¹⁾ Length and weight of optional stainless steel model may differ

²⁾ Weight is for DIN PN 25/40 ³⁾ P46SRW only

⁴⁾ Weight is for ASME Class 600RF

Discharge Capacity

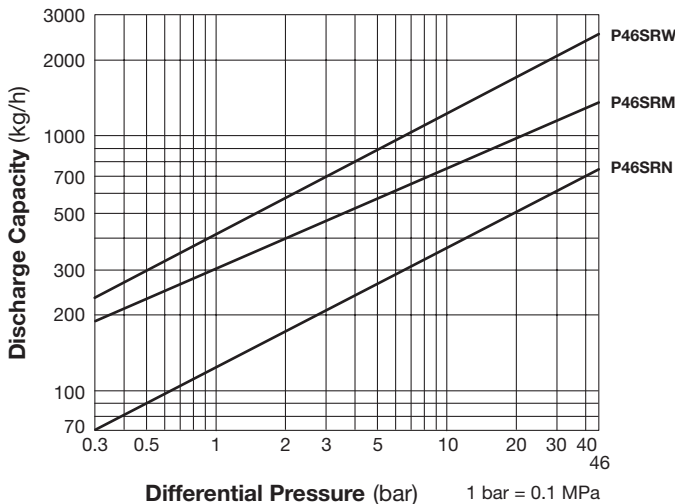

- Differential pressure is the difference between the inlet and outlet pressure of the trap.
- Recommended safety factor: at least 2.

Pressure Temperature Rating*

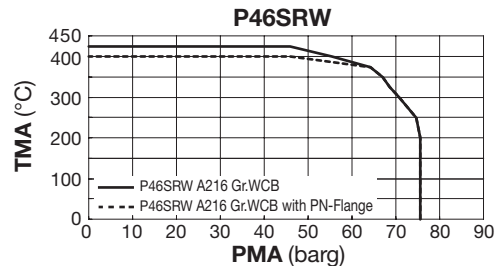
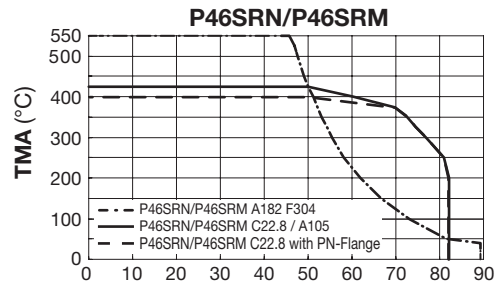

* These Rating Graphs are based on Allowable Stress Values of ASTM-Materials at each temperature.