



SS1VG

Stainless Steel Free Float Drain Trap

Features

All stainless steel trap, to be installed in pipe ends. Automatically drains condensate from air and inert gas systems.

1. Constant water seal and unique rotational seating design prevent concentrated wear to ensure long life.
2. Three-point seating provides a tight seal even under no-load conditions (with rubber sealing).
3. Precision ground float guarantees superior sealing.
4. Built-in screen with large surface area ensures extended trouble-free operation.
5. Self-modulating free float provides continuous, smooth, low velocity condensate discharge as process loads vary.



Specifications

Model	SS1VG-R (Rubber Orifice)	SS1VG-M (Metal Orifice)
Connection	Screwed	
Size	1/2", 3/4", 1"	
Orifice No.	10	G5, G10, G16, G21
Maximum Operating Pressure (barg) PMO**	10	5, 10, 16, 21
Maximum Differential Pressure (bar) ΔPMX**	10	5, 10, 16, 21
Maximum Operating Temperature (°C) TMO	150	220
Minimum Condensate Load for Tight Sealing (kg/h)	0	0.5
Applicable fluid	Air, Inert Gas*	

* Do not use for toxic, flammable, or otherwise hazardous gases.

PRESSURE SHELL DESIGN CONDITIONS (NOT OPERATING CONDITIONS): Maximum Allowable Pressure (barg) PMA: 21
Maximum Allowable Temperature (°C) TMA: 220

** For specific gravities other than 1.00, use table below

Model	Orifice No.	Specific Gravity										
		1.00	0.99-0.95	0.94-0.90	0.89-0.85	0.84-0.80	0.79-0.75	0.74-0.70	0.69-0.65	0.64-0.60	0.59-0.55	0.54-0.50
Maximum Operating Pressure PMO (barg) & Maximum Differential Pressure ΔPMX (bar)												
SS1VG-R	10	10.0	9.9	8.9	7.9	6.9	5.9	4.9	3.9	2.8	1.8	0.8
SS1VG-M	G5	5.0	4.9	4.4	3.9	3.4	2.9	2.4	1.9	1.4	0.9	0.4
	G10	10.0	9.9	8.9	7.9	6.9	5.9	4.9	3.9	2.8	1.8	0.8
	G16	16.0	15.0	13.5	12.0	10.4	8.9	7.4	5.9	4.3	2.8	1.3
	G21	21.0	20.6	18.5	16.4	14.3	12.2	10.1	8.0	5.9	3.8	1.7

1 bar = 0.1 MPa



To avoid abnormal operation, accidents or serious injury, DO NOT use this product outside of the specification range. Local regulations may restrict the use of this product to below the conditions quoted.

No.	Description	Material	DIN*	ASTM/AISI*
①	Body	Cast Stainless Steel A351 Gr.CF8	1.4312	—
②	Cover	Cast Stainless Steel A351 Gr.CF8	1.4312	—
③	Float	Stainless Steel SUS316L	1.4404	AISI316L
④	Orifice (Metal)	—	—	—
	Orifice (Rubber)	Stainl. Stl. SUS303/FPM	1.4305/FPM	AISI303/D2000HK
⑤	Orifice Gasket	Fluorine Resin PTFE	PTFE	PTFE
⑥	Screen	Stainless Steel SUS304	1.4301	AISI304
⑦	Cover Gasket	Fluorine Resin PTFE	PTFE	PTFE
⑧	Cover Bolt	Stainless Steel SUS304	1.4301	AISI304
⑨	Nameplate	Stainless Steel SUS304	1.4301	AISI304

* Equivalent materials

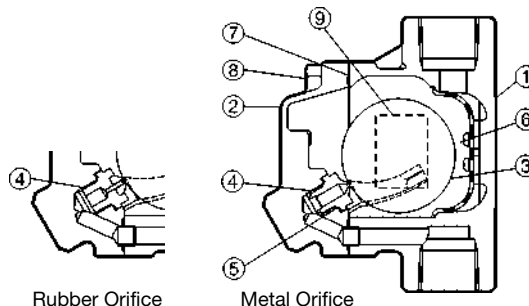

Dimensions

● SS1VG Screwed

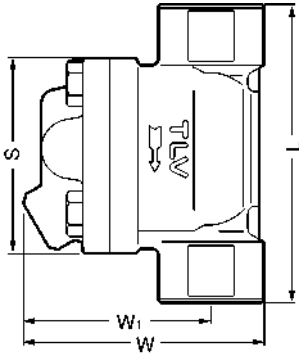

SS1VG Screwed*

(mm)

Size	L	W	W ₁	S	Weight (kg)
1/2"	110	103	82	85	1.6
3/4"	120				1.7
1"	130				1.8

* BSP DIN 2999, other standards available

NOTE

Install the shortest possible vertical condensate pipe to the trap to ensure unobstructed condensate flow.

Discharge Capacity

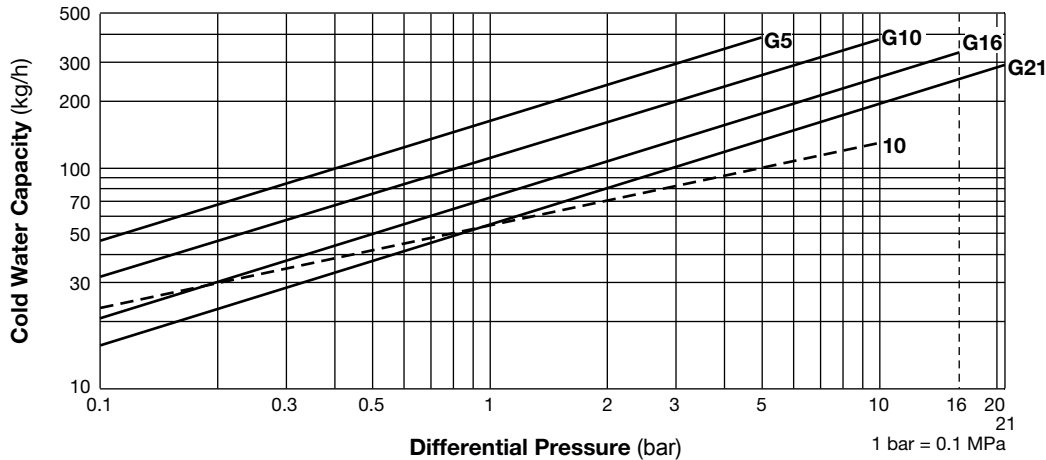

----- Rubber Orifice ———— Metal Orifice

1. Line numbers within the graph refer to orifice numbers.
2. Differential pressure is the difference between the inlet and outlet pressure of the trap.
3. The chart is applicable to condensate below 100 °C.
4. The discharge capacity is for a liquid with specific gravity of 1.
5. Recommended safety factor: at least 1.5.



CAUTION DO NOT use traps under conditions that exceed maximum differential pressure, as condensate backup will occur!

Capacity Conversion Factors

Specific Gravity	0.95	0.9	0.85	0.8	0.75	0.7	0.65	0.6	0.55	0.5
Conversion Factor	1.03	1.06	1.08	1.12	1.16	1.19	1.24	1.29	1.35	1.41

Before using the capacity chart, multiply the required capacity (including safety factor) by the appropriate conversion factor for the specific gravity of the liquid. Choose from the table above or use the following formula: Conversion factor = $\frac{1}{\sqrt{S.G.}}$