

# ART 350

## PN32 Bronze Globe Valve



### Features

- Screwed BSP Taper (ISO 7/1)
- Union bonnet
- Rising stem
- PTFE renewable disc
- BS 5154 (BS EN12288)

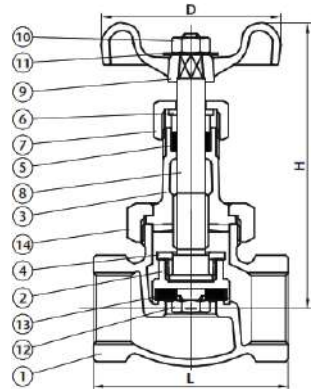

### Technical data

Max pressure: 32 Bar

Working temp: -10°C to +200°C

DN	1/2"	3/4"	1"	1 1/4"	1 1/2"	2"
L	57.0	67.0	76.5	88.0	102.5	121.5
H	89	101	116	128	142	167
D	62	68	80	90	102	111
Kv	3.0	5.7	10.4	19.0	26.0	43.3
Kgs	0.46	0.66	0.98	1.44	2.16	3.23

### N. Part Name

### Materials

1 Body	Bronze ASTM B62 C83600
2 Disc Holder 1/2" & 3/4"	Brass ASTM B16 C36000
2 Disc Holder 1" - 2"	Bronze ASTM B62 C8600
3 Cap	Bronze ASTM B62 C83600
4 Lock Nut	Brass ASTM B16 C36000
5 Stem Packing	Teflon PTFE
6 Gland	Brass ASTM B16 C36000
7 Packing Nut	Brass ASTM B16 C36000
8 Stem	DZR
9 Handwheel	Cast Iron ASTM A126 Class B
10 Wheel Nut	Steel Zn Plated ASTM A563
11 Nameplate	Aluminium ASTM B29 1100
12 Disc Nut 1/2" & 3/4"	Brass ASTM B16 C36000
12 Disc Nut 1" - 2"	Bronze ASTM B62 C83600
13 Disc Teflon	Glass field with PTFE
14 Union Nut	Bronze ASTM B62 C83600

