

# ART 345

## PN40 Bronze Ball Valve



### Technical data

Max pressure: 40 Bar  
Working temp: -10°C to +140°C

### Features

- Available in Screwed BSP Taper (ISO 7/1) or NPT (ANSI B1.20.1)
- Full bore
- Anti-blow-out stem
- MSS-SP-110

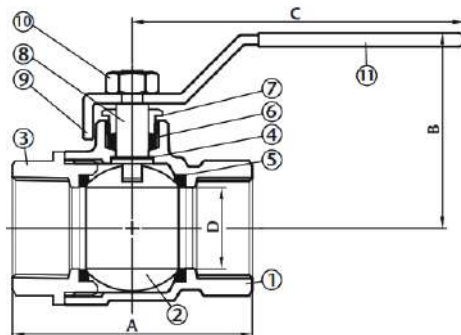

DN	1/2"	3/4"	1"	1 1/4"	1 1/2"	2"
A	54.5	62.0	73.1	82.5	91.7	106.5
B	46	55	62	70	75	82
C	82	103	105	106	150	160
D	12.7	19.0	25.0	31.0	38.0	50.0
Kv	8.3	20.0	28.3	41.6	62.4	91.6
Kgs	0.22	0.35	0.56	0.71	1.15	1.92

### N. Part Name Materials

1	Body	Bronze ASTM B62 C83600
2	Ball*	Brass/Chrome Plated ASTM B16 CA360
3	Cap	Bronze - ASTM B62 C83600
4	Thrust Washer	PTFE
5	Ball Seats	PTFE
6	Stem Packing	PTFE
7	Packing Guard	Brass - ASTM B16 CA360
8	Stem	Brass - ASTM B16 CA360
9	Handle	Steel - ASTM A107
10	Handle Nut	Steel - ASTM A107
11	Sleeve	Vinyl

\*1/2" - 3/4" Solid Ball. 1" - 2" Hollow Ball

