

ART 160

PN40 Brass Ball Valve

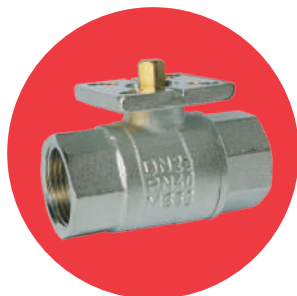

Features

- Screwed BSP Parallel (ISO 228/1)
- PTFE seats & seals
- ISO 5211 Direct Mount
- Low torque

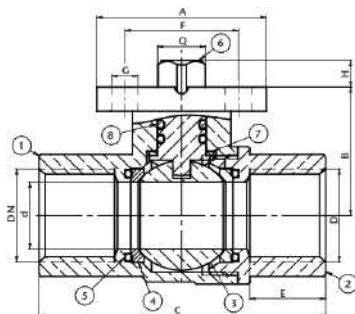

Technical data

Max pressure: $\frac{1}{4}$ " - 1" 40 Bar
 $1\frac{1}{4}$ " 32 Bar
 $1\frac{1}{2}$ " - $2\frac{1}{2}$ " 30 Bar
 3" 25 Bar

Working temp: -20°C to +120°C

DN	1/4"	3/8"	1/2"	3/4"	1"	1 1/4"	1 1/2"	2"	2 1/2"	3"
d	11.5	15	15	20	25	32	38	45	62	76
A	38	38	38	38	50	50	50	50	70	70
B	29	29	29	32	36	41	57	64	90	100
C	64	64	64	76	88	96	103	121	165	188
G	6	6	6	6	7	7	7	7	8.5	8.5
E	17	17	17	19	21	22	22	25	34	37
F	36	36	36	36	50	50	50	50	70	70
Drilling	F03	F03	F03	F03	F05	F05	F05	F05	F07	F07
Q	9	9	9	9	9	9	11	11	14	14
H	10	10	10	10	10	10	12	12	16	16
Torque	3	3	3	4	5	10	15	15	20	20
Kv	5.4	6.0	16.20	43.00	89.00	230.00	264.00	538.00	870.0	
Kgs	0.34	0.31	0.28	0.48	0.71	0.94	0.94	1.96	3.00	5.90

Torque calculated at zero pressure includes 25% safety, add 25% for dry duty.

N.	Part Name	Materials
1	Body	Brass / Chrome Plated CW617N
2	Cap	Brass / Chrome Plated CW617N
3	Ball	Brass / Chrome Plated CW617N
4	Seat	PTFE
5	O-Ring	PTFE
6	Stem	Brass / Nickel Plated CW614N
7	Washer	PTFE
8	O-Ring	Viton

