

FlexLock Coupling

Specifications

- 1) Sleeve
- 2) End Ring
- 3) Gasket
- 4) Gripper Teeth
- 5) Bolt

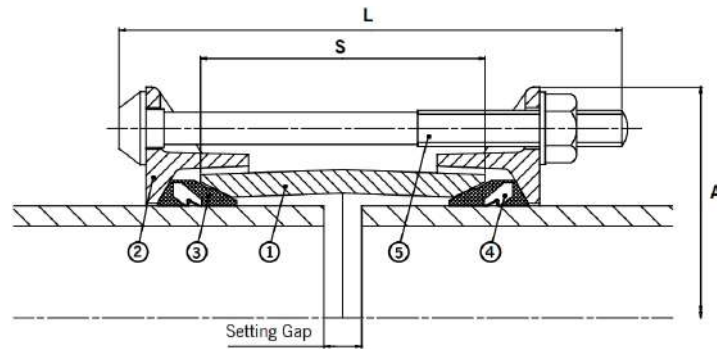

Pipe Nom	Pipe OD (mm)	Pipe Material	Bolt Size No.-Dia x Length	Overall Length (L)	End Ring OD (A)	Sleeve Length x Thickness (mm) (S)	Setting Gap		Working Pressure (bar)		Gasket Mould	Coupling Weight (kg)
							Min	Max	Water	Gas		
DN50/2"	60.3	Steel	2-M12 x 145	157	135	80 x 5.5	15	30	16	6	1375	2.7
DN65/2.5"	76.1/77	Steel	2-M12 x 160	170	152	100 x 6.0	20	40	16	6	1394	3.2
DN80/3"	88.9	Steel	4-M12 x 160	170	163	100 x 6.0	20	40	16	6	1382	4.2
DN80/3"	98.0	Ductile Iron	4-M12 x 195	203	181	115 x 6.4	20	40	16	6	1630	5.2
DN100/4"	114.3	Steel	4-M12 x 170	188	195	100 x 6.0	20	40	16	6	1367	6.1
DN100/4"	118	Ductile Iron	4-M12 x 195	203	200	115 x 6.4	20	40	16	6	1618	5.6
DN150/6"	165.1	Steel	6-M12 x 170	188	254	100 x 7.2	20	40	16	6	1369	9.2
DN150/6"	168.3	Steel	6-M12 x 170	188	256	100 x 7.2	20	40	16	6	1369	9.3
DN150/6"	170	Ductile Iron	6-M12 x 170	178	256	100 x 7.2	20	40	16	6	1369	9.2
DN200/8"	219.1	Steel	8-M12 x 170	188	310	100 x 7.2	20	40	16	6	1370	11.9
DN200/8"	222	Ductile Iron	6-M16 x 195	206	316	115 x 6.4	20	40	16	6	1631	12.0
DN250/10"	273.0	Steel	12-M16 x 275	286	376	178 x 8.5	20	40	10	6	1737	32.2
DN250/10"	274	Ductile Iron	12-M16 x 275	286	376	178 x 8.5	20	40	10	6	1737	32.2
DN300/12"	323.9	Steel	12-M16 x 275	286	436	178 x 6.0	20	40	10	6	7667/8	33.7
DN300/12"	326	Ductile Iron	12-M16 x 275	286	436	178 x 6.0	20	40	10	6	7667/8	33.7

FlexLock bolt torques: M12 = 55-65Nm M16 = 95-120Nm

Materials & Relevant Standards

Centre Sleeve/End Rings

SG. Iron to BS 1563: Symbol EN-GJS-450-10
or Rolled Steel to: BS EN 10025: Grade S275.

Coupling Body

Ductile Iron to BS EN 1563 EN-GJS-450-10.
or Mild Steel to: BS EN 10025: Grade S275.

Bolts/Nuts/Washers

Bolts - Cold Forged Steel Fasteners to: BS EN ISO898-1:
Property Class 8.8

Nuts - Steel BS EN 20898-2: Property Class 8

Washers - BS 4320 Form B Stainless Steel BS 1449:PT2: Grade 304 S15

Coatings

Body, Centre Sleeve, End Rings are coated in Rilsan Nylon 11
to WIS 4-52-01 Part 1.

Bolts, studs and nuts are Sheraplex coated to WIS 4-52-03.

Gaskets

EPDM compound Grade 'E' to BS EN 681-1 WRAS listed.

Suitable for: water, sewage, many strong and oxidising chemicals
and food applications.

Nitrile compound Grade 'G' to BS EN 682-1.

Suitable for: natural gas, petroleum products, low aromatic fuels, compressed
air, sewage and drainage.

Stainless Steel teeth in gaskets BS 3146: Part 2 Grade ANC2.

Approvals/Standards

Designed and manufactured under quality management systems to BS EN
ISO 9001. They have been tested in accordance with the requirements of
WRc Water Bye-laws Scheme and conform to the American Water Works
Associations standard AWWA/ANSI C.219 for bolted couplings.

Note: 1) For coated steel pipe the maximum permitted coating thickness is 500µ DFT. This is to ensure the stainless steel teeth properly grip onto the pipe surface to mobilize the end load capability of the products. 2) Due to the surface characteristics of stainless steel pipe, FlexLock grippers are unable to achieve a guaranteed grip on the pipe surface. 3) FlexLock is suitable for use on cold potable water pipelines and has a maximum operating temperature of 40°C.