

Butt Weld Fittings to ASME B16.9 (BS 1640)

Long & Short Radius Elbows

Normal Pipe Size		Outside Diameter Y	Wall Thickness T		45 Elbow Long Radius Centre to Face B	Approx Weight	90 Elbow Long Radius Centre to Face A	Approx Weight	90 Elbow Short Radius Centre to Face A	Approx Weight
mm	in		mm	Schedule						
15	1/2"	21.3	2.78	STD	15.9	0.04	38.1	0.08	-	-
			3.73	X.S						
20	3/4"	26.7	2.87	STD	11.1	0.04	28.6	0.08	-	-
			3.91	X.S						
25	1"	33.4	3.38	STD	22.2	0.09	38.1	0.15	25.4	0.11
			4.55	X.S						
32	1 1/4"	42.2	3.56	STD	25.4	0.14	47.6	0.28	31.75	0.18
			4.85	X.S						
40	1 1/2"	48.3	3.68	STD	28.6	0.2	57.1	0.4	38.1	0.26
			5.08	X.S						
50	2"	60.3	3.91	STD	34.9	0.36	76.2	0.72	50.8	0.5
			5.54	X.S						
65	2 1/2"	73.0	5.16	STD	44.4	0.73	95.2	1.46	63.5	0.95
			7.01	X.S						
80	3"	88.9	5.49	STD	50.8	1.1	114.3	2.18	76.2	1.45
			7.62	X.S						
100	4"	114.3	6.02	STD	63.5	2.1	152.4	4.2	101.6	2.8
			8.56	X.S						
125	5"	141.3	6.65	STD	79.4	3.4	190.0	6.8	127.0	4.8
			9.5	X.S						
150	6"	168.3	7.11	STD	95.2	5.1	229.0	10.1	152.4	6.8
			10.97	X.S						
200	8"	219.1	8.18	STD	127.0	10.2	305.0	20.4	203.0	13.6
			12.7	X.S						
250	10"	273.9	9.27	STD	159.0	18.1	381.0	36.1	254.0	24.1
			12.7	X.S						
300	12"	323.9	9.52	STD	190.0	26.6	457.0	53.1	305.0	35.4
			12.7	X.S						
350	14"	355.6	9.52	STD	222.0	34.1	533.0	68.1	356.0	45.4
			12.7	X.S						
400	16"	406.4	9.52	STD	254.0	45.0	610.0	89.3	406.0	59.5
			12.7	X.S						
450	18"	457.0	9.52	STD	286.0	56.5	686.0	113.0	457.0	75.6
			12.7	X.S						
500	20"	508.0	9.52	STD	318.0	85.0	762.0	140.0	508.0	93.5
			12.7	X.S						
600	24"	610.00	9.52	STD	381.0	101.5	914.0	203.0	610.0	135.0
			12.7	X.S						

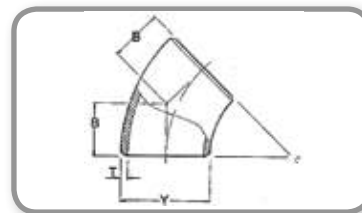
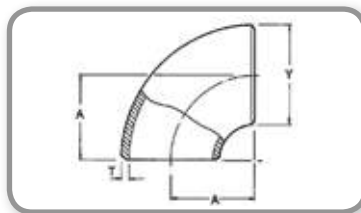
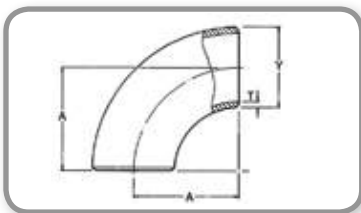

E&OE

Butt Weld Fittings to ASME B16.9 (BS 1640) Equal Tees & End Caps

Normal Pipe Size		Outside Diameter Y	Wall Thickness T		Tees (C&M)	Approx Weight	Caps End to E	Approx Weight
mm	in	mm	mm	Schedule	mm	mm	mm	kg
15	1/2"	21.3	2.78	STD	25.4	0.58		
			3.73	X.S	25.4	0.21		
20	3/4"	26.7	2.87	STD	28.6	0.21		
			3.91	X.S	28.6	0.27		
25	1"	33.4	3.38	STD	38.1	0.34	38.1	0.1
			4.55	X.S	38.1	0.43	38.1	0.14
32	1 1/4"	42.2	3.56	STD	47.6	0.64	38.1	0.14
			4.85	X.S	47.6	0.75	38.1	0.18
40	1 1/2"	48.3	3.68	STD	57.1	0.95	38.1	0.18
			5.08	X.S	57.1	1.13	38.1	0.23
50	2"	60.3	3.91	STD	63.5	1.45	38.1	0.27
			5.54	X.S	63.5	1.72	38.1	0.32
65	2 1/2"	73.0	5.16	STD	76.2	2.45	38.1	0.41
			7.01	X.S	76.2	2.95	38.1	0.45
80	3"	88.9	5.49	STD	85.7	3.45	50.8	0.64
			7.62	X.S	85.7	4.3	50.8	0.82
100	4"	114.3	6.02	STD	105.0	5.7	63.5	1.13
			8.56	X.S	105.0	7.3	63.5	1.54
125	5"	141.3	6.65	STD	124.0	9.1	76.2	1.91
			9.5	X.S	124.0	11.8	76.2	2.59
150	6"	168.3	7.11	STD	143.0	13.6	88.9	2.95
			10.97	X.S	143.0	19.0	88.9	4.1
200	8"	219.1	8.18	STD	178.0	25.0	101.6	5.0
			12.7	X.S	178.0	33.5	101.6	7.3
250	10"	273.0	9.27	STD	216.0	41.0	127.0	9.1
			12.7	X.S	216.0	54.0	127.0	12.0
300	12"	323.9	9.52	STD	254.0	57.0	152.4	13.6
			12.7	X.S	254.0	77.0	152.4	17.0
350	14"	355.6	9.52	STD	279.0	73.0	165.1	15.9
			12.7	X.S	279.0	93.0	165.1	21.0
400	16"	406.4	9.52	STD	305.0	91.0	178.8	20.0
			12.7	X.S	305.0	120.0	178.8	26.0
450	18"	457.0	9.52	STD	343.0	127.0	203.2	26.0
			12.7	X.S	343.0	165.0	203.2	34.0
500	20"	508.0	9.52	STD	381.0	227.0	228.6	33.0
			12.7	X.S	381.0	270.0	228.6	43.0
600	24"	610.0	9.52	STD	432.0	345.0	266.7	46.0
			12.7	X.S	432.0	430.0	266.7	61.0

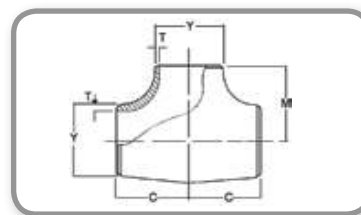
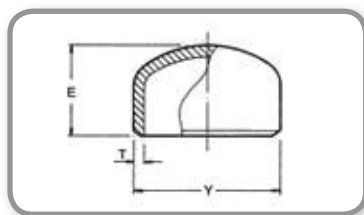

E&OE

Butt Weld Fittings to ASME B16.9 (BS 1640) Concentric & Eccentric Reducers

Normal Pipe Size Y		Length H	Schedule T	Approx Weight
mm	in	mm		Kg
20x15	3/4"x1/2"	38.1	STD	0.07
			X.S	0.1
25x15	1"x1/2"	50.8	STD	0.14
			X.S	0.18
25x20	1"x3/4"	50.8	STD	0.14
			X.S	0.18
32x15	1 1/4"x1/2"	50.8	STD	0.18
			X.S	0.23
32x20	1 1/4"x3/4"	50.8	STD	0.18
			X.S	0.23
32x25	1 1/4"x1"	50.8	STD	0.18
			X.S	0.23
40x15	1 1/2"x1/2"	63.5	STD	0.27
			X.S	0.32
40x20	1 1/2"x3/4"	63.5	STD	0.27
			X.S	0.32
40x25	1 1/2"x1"	63.5	STD	0.27
			X.S	0.32
40x32	1 1/2"x1 1/4"	63.5	STD	0.27
			X.S	0.32
50x15	2"x1/2"	76.2	STD	0.41
			X.S	0.54
50x20	2"x3/4"	76.2	STD	0.41
			X.S	0.54
50x25	2"x1"	76.2	STD	0.41
			X.S	0.54
50x32	2"x1 1/4"	76.2	STD	0.41
			X.S	0.54
50x40	2"x1 1/2"	76.2	STD	0.41
			X.S	0.54
65x25	2 1/2"x1"	88.9	STD	0.68
			X.S	0.91
65x32	2 1/2"x1 1/4"	88.9	STD	0.68
			X.S	0.91

Normal Pipe Size Y		Length H	Schedule T	Approx Weight
mm	in	mm		Kg
65x40	2 1/2"x1 1/2"	88.9	STD	0.68
			X.S	0.91
65x50	2 1/2"x2"	88.9	STD	0.68
			X.S	0.91
80x40	3"x1 1/2"	88.9	STD	0.77
			X.S	1.09
80x50	3"x2"	88.9	STD	0.91
			X.S	1.22
80x65	3"x2 1/2"	88.9	STD	0.91
			X.S	1.27
100x40	4"x1 1/2"	101.6	STD	1.36
			X.S	1.91
100x50	4"x2"	101.6	STD	1.40
			X.S	1.95
100x65	4"x2 1/2"	101.6	STD	1.45
			X.S	2.04
100x80	4"x3"	101.6	STD	1.59
			X.S	2.08
125x80	5"x3"	127.0	STD	2.5
			X.S	3.4
125x100	5"x4"	127.0	STD	2.7
			X.S	3.8
150x50	6"x2"	140.0	STD	3.4
			X.S	4.3
150x65	6"x2 1/2"	140.0	STD	3.4
			X.S	4.5
150x80	6"x3"	140.0	STD	3.6
			X.S	4.8
150x100	6"x4"	140.0	STD	3.7
			X.S	5.2
150x125	6"x5"	140.0	STD	3.9
			X.S	5.4

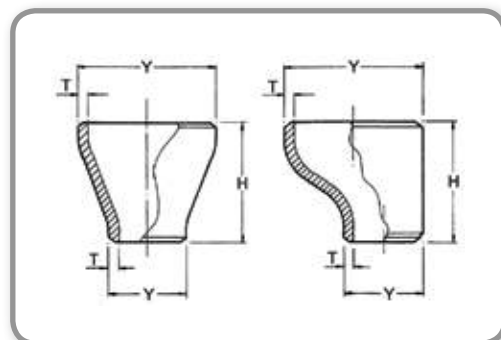

E&OE

Butt Weld Fittings to ASME B16.9 (BS 1640) Concentric & Eccentric Reducers

Normal Pipe Size Y		Length H	Schedule T	Approx Weight
mm	in	mm		Kg
200x80	8"x3"	152.4	STD	4.5
			X.S	7.2
200x100	8"x4"	152.4	STD	5.0
			X.S	7.7
200x125	8"x5"	152.4	STD	5.4
			X.S	8.2
200x150	8"x6"	152.4	STD	5.9
			X.S	8.6
250x100	10"x4"	178.0	STD	9.1
			X.S	11.8
250x125	10"x5"	178.0	STD	9.5
			X.S	13.6
250x150	10"x6"	178.0	STD	9.5
			X.S	13.6
250x200	10"x8"	178.0	STD	10.0
			X.S	14.0
300x150	12"x6"	203.0	STD	14.1
			X.S	18.1
300x200	12"x8"	203.0	STD	14.5
			X.S	19.1
300x250	12"x10"	203.0	STD	15.4
			X.S	20.0
350x200	14"x8"	330.0	STD	26.3
			X.S	34.9
350x250	14"x10"	330.0	STD	27.2
			X.S	36.3
350x300	14"x12"	330.0	STD	28.6
			X.S	37.6
400x200	16"x8"	356.0	STD	31.8
			X.S	42.6
400x250	16"x10"	356.0	STD	33.1
			X.S	43.5
400x300	16"x12"	356.0	STD	34.5
			X.S	45.4

Normal Pipe Size Y		Length H	Schedule T	Approx Weight
mm	in	mm		Kg
400x350	16"x14"	356.0	STD	35.4
			X.S	46.3
450x250	18"x10"	381.0	STD	38.0
			X.S	52.1
450x300	18"x12"	381.0	STD	39.0
			X.S	53.5
450x350	18"x14"	381.0	STD	40.0
			X.S	54.9
450x400	18"x16"	381.0	STD	40.8
			X.S	53.5
500x250	20"x10"	508.0	STD	53.0
			X.S	79.9
500x300	20"x12"	508.0	STD	54.4
			X.S	82.0
500x350	20"x14"	508.0	STD	57.6
			X.S	80.2
500x400	20"x16"	508.0	STD	58.9
			X.S	82.0
500x450	20"x18"	508.0	STD	61.7
			X.S	82.0
600x300	24"x12"	508.0	STD	63.5
			X.S	84.4
600x350	24"x14"	508.0	STD	65.3
			X.S	86.8
600x400	24"x16"	508.0	STD	68.0
			X.S	90.4
600x450	24"x18"	508.0	STD	72.6
			X.S	96.5
600x500	24"x20"	508.0	STD	77.1
			X.S	102.5

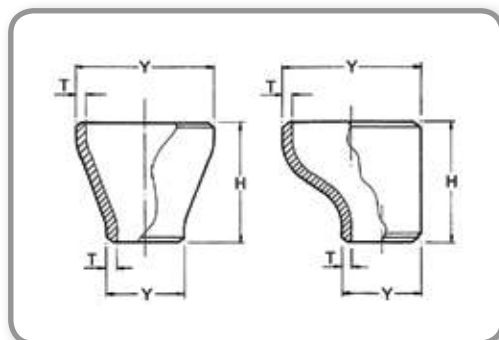

E&OE